

Motor Cable Color Connection Diagram

TIV25F

Motor - side connection

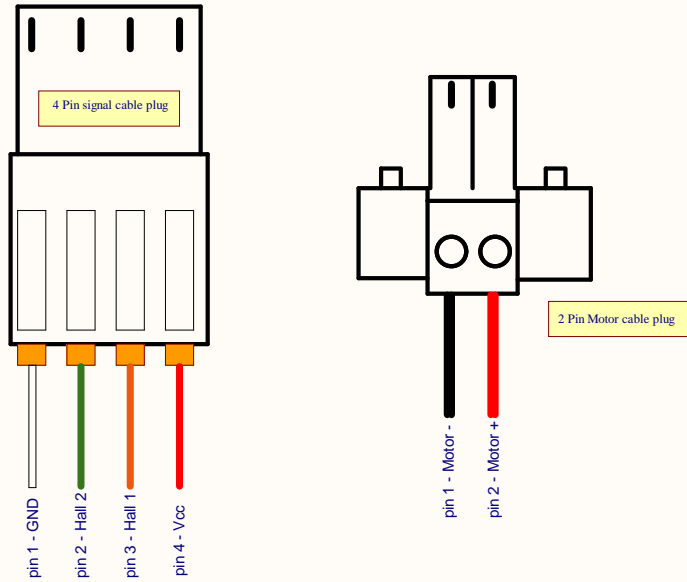

TIV25E

Motor - side connection

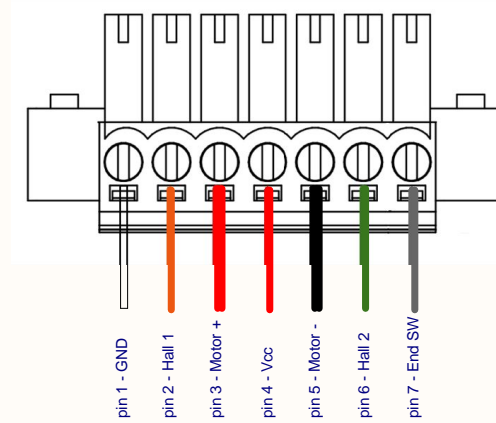

Positioner - side connection

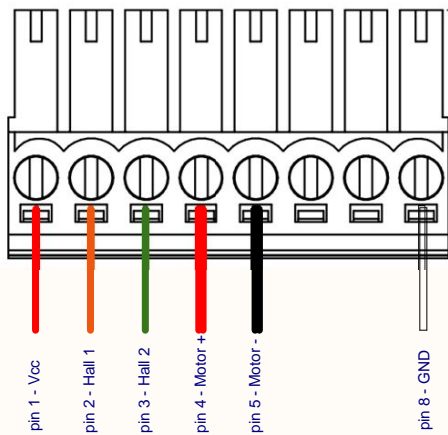

TIV36F positioner

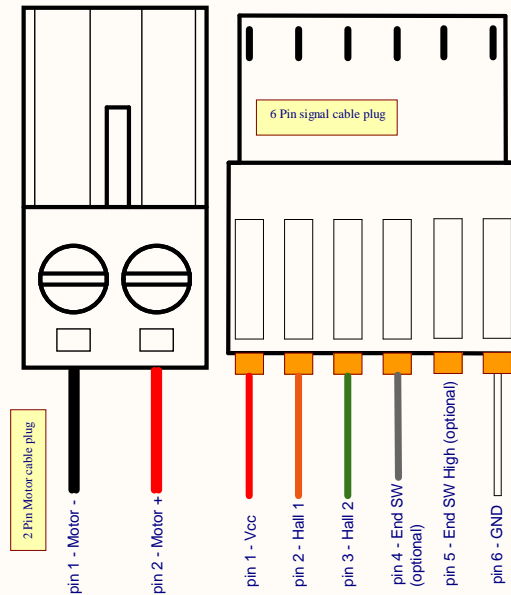

Positioner - side connection

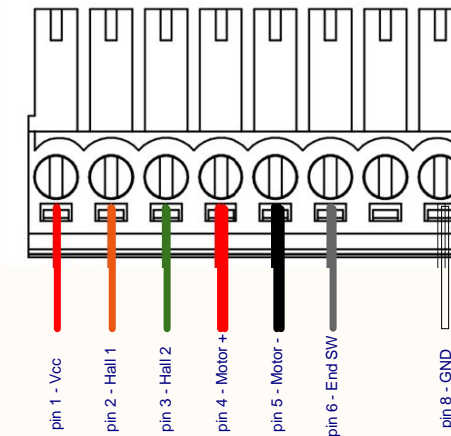

Title		
Size	Number	Revision
A3		
Date:	3.16.2022	Sheet of
File:	\\.\Priklop-Motor.SchDoc	Drawn By: