



INSA-6120-RS485

Modbus Single-Axis Inclinometer

Data sheet and technical manual



INTRODUCTION

INSA-6120-RS485 is a digital output low-cost single-axis inclinometer, adopting the latest industrial level MEMS accelerometer. Its measuring range is $\pm 180^\circ$, highest accuracy of 0.3° , working temperature is $-40^\circ\text{C} \sim +85^\circ\text{C}$, the product with a small-volume and low weight, can meet space-restricted application requirements.

This product converts static gravity field changes into angle changes, It outputs horizontal angle values directly by digital, this product has the advantages of low-cost, small temperature drift, simple to use, and strong resistance to external disturbances. It is an ideal option for attitude measurement in photovoltaic power (PV), PTZ control, tower turbines monitoring and other industries.

FEATURES

- Single-axis inclinometer measurement
- Resolution: 0.03°
- Voltage input: 9~35V
- Product size: L55mm×W37mm×H24mm (customizable)
- Accuracy: 0.3°
- Measuring range: $\pm 180^\circ$
- IP67 protection
- Output interface: RS232/485/TTL optional

APPLICATIONS

- Industrial automatic leveling
- Medical devices
- PV automatic tracking
- Tower tilt monitoring
- Special valves
- Oil drilling equipment
- Industrial converters
- Crane tilt angle control

/// SPECIFICATIONS

Electrical Specifications

Parameters	Conditions	Min	Typical	Max	Units
Power supply		9	24	35	V
Operating current	Non-loaded	20	30	40	mA
Operating temperature		-40		-85	°C
Store temperature		-55		+100	°C

Performance Specifications

Mesasuring range	Conditions	±180°
Measuring axis	Mutually perpendicular	X
Accuracy	Room temprature	0.3
Resolution	Completely still	0.03
Zero temperature drift (°/° C)	-40~85°C	±0.03
Cross axis error (°)	-40~85°C	0.3
Start-up time		<3 s
Output frequency (Hz)	5-100Hz adjustable	Up to 100
Mean time between failures MTBF	≥90000 h	
Electromagnetic compatibility	According to GBT17626	
Insulation resistance	≥100 MΩ	
Impact resistance	2000 g, 0.5 ms, 3 times/axis	
Weight (g)	210 (package excluded)	

Resolution: The measured minimum change value that the sensor can detect and resolve within the measurement range.

Accuracy: The error between the actual angle and the Root mean square(RMS) of the measured angle of the sensor (≥16 times).



Mechanical Characteristic

Connector	Metal connector (standard cable is 1.5 m)
Protection level	IP67
Shell material	Magnesium alloy sanding oxidation
Installation	Three M4 screws



Package size

Product Size: L55*W37*H24 (mm)

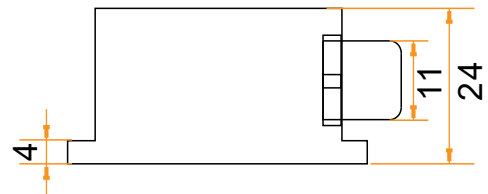
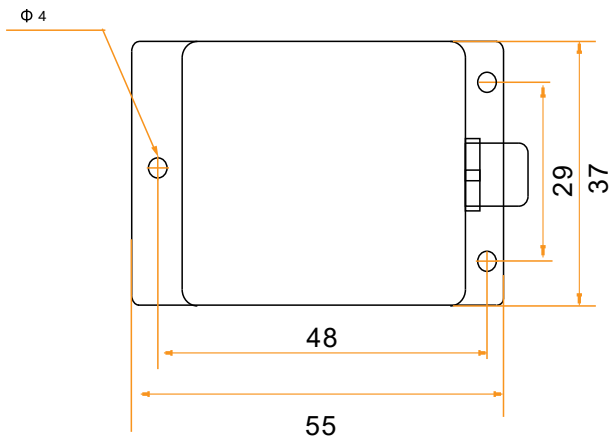

Bare plate product size

Product size: L33*W27*H6 (mm)

Note: ± 1 mm error for length and width dimensions, please refer to actual size.

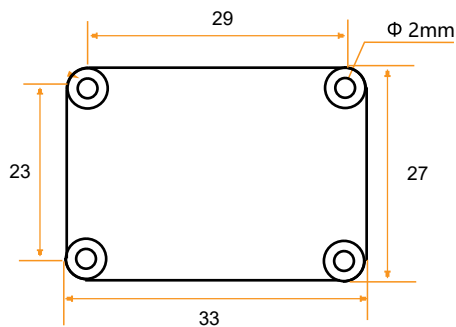

/// INSTALLATION DIRECTION

The correct installation method can avoid measurement error. The following points should be made when installing the sensor:

First of all, to ensure that the sensor mounting surface and the measured surface completely close, the measured surface should be as horizontal as possible, can not have the angle shown in Figure A and Figure C, the correct installation is shown in Figure B and Figure D.

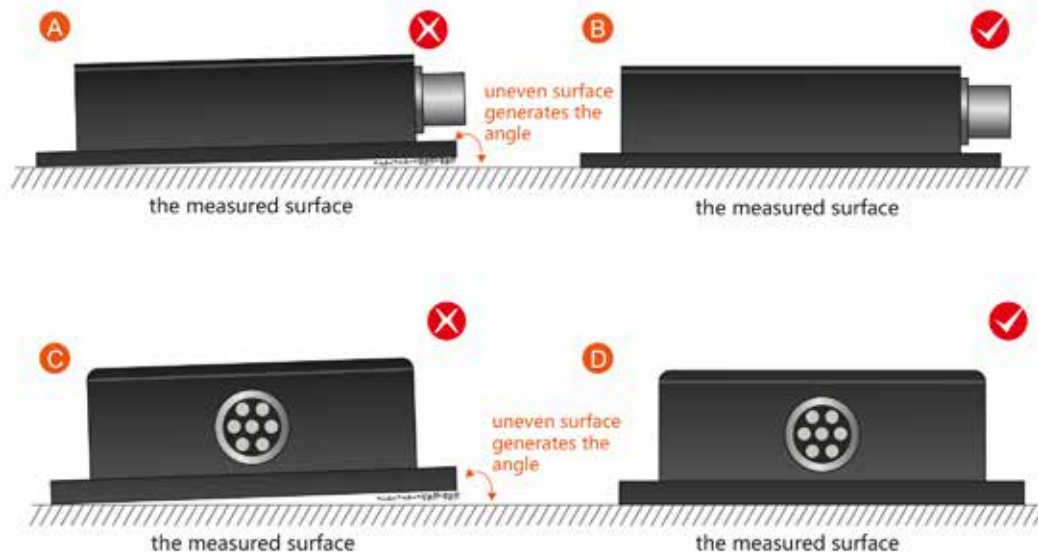

Secondly, the bottom cable of the sensor and the axis of the measured object shouldn't generate the angle shown in E. When installing, the bottom cable of the sensor should be kept parallel or orthogonal to the rotation axis of the measured object. This product can be installed horizontally or vertically (vertical installation requires customization). The correct installation method is shown in Figure F.

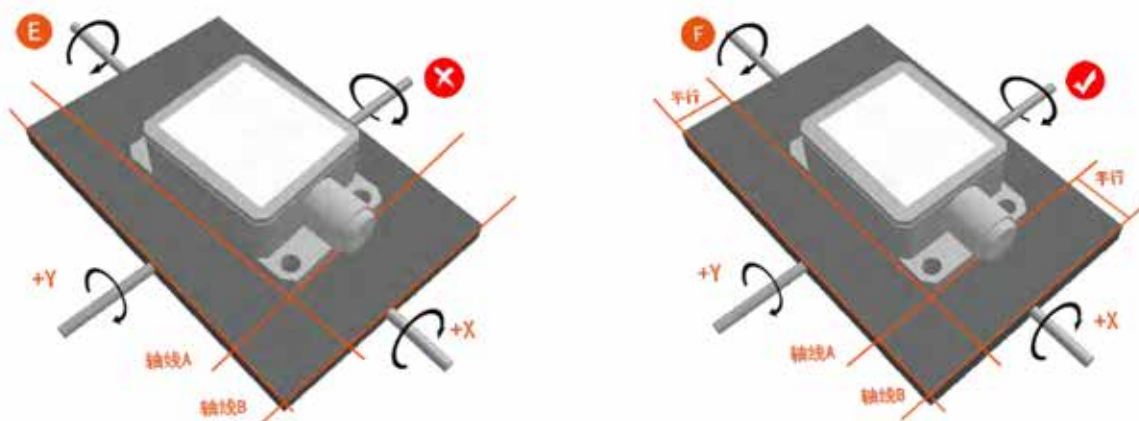

Finally, the installation surface of the sensor must be fixed with the measured surface tightly and smoothly, to avoid measurement error that may be caused by the acceleration and vibration.

ELECTRICAL CONNECTIONS

Electrical interfaces

Cable color & Function	Red	Blue	Black	Green	Yellow
	1	2	3	4	5
Function	VCC DC 9-35V	NC	GND	RXD (B, D-)	TXD (A, D+)

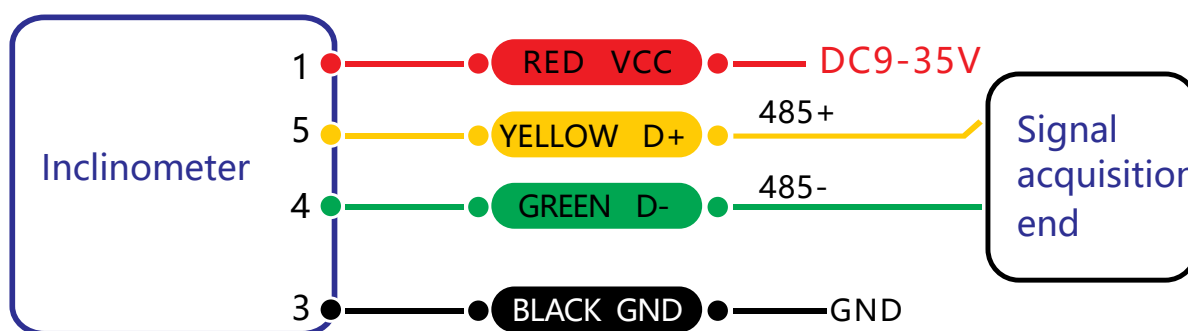

RS 485 wiring diagram

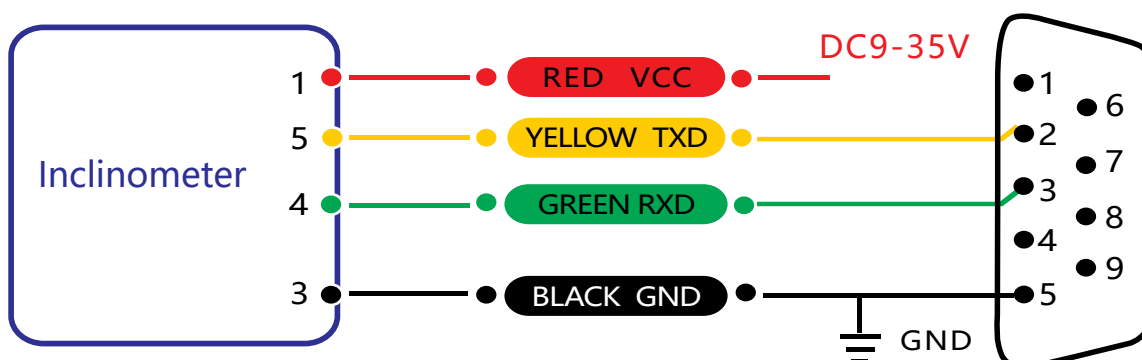

RS 232 wiring diagram

INSA-6120-RS485

Modbus Single-Axis Inclinator

Sat Control d.o.o.

Požnik 10
4207 Cerklje na Gorenjskem
Slovenia

Phone: +386 4 281 62 00

info@solar-motors.com
info@sat-control.si

www.solar-motors.com
www.sat-control.net

EU RoHS 

SAT CONTROL
SOLAR TRACKERS