

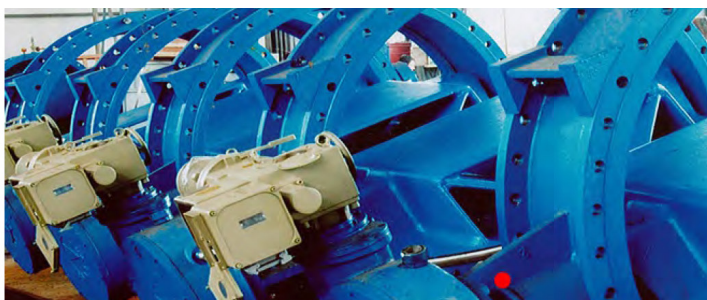

IM-SA-RT02 Series

Modbus Single-Axis Inclinometer

Data sheet and technical manual



INTRODUCTION

Designed by Sat Control, IM-SA-RT02 is a digital output low cost single-axis inclinometer, adopting the latest industrial level MEMS accelerometer. Its measuring range is $\pm 180^\circ$, highest accuracy is 0.2° , working temperature is $-40^\circ\text{C} \sim +85^\circ\text{C}$, the product with a small size and low weight, can meet space-restricted application requirements.

This product converts static gravity field changes into angle changes, It outputs horizontal angle values directly by digital, this product has the advantages of low cost, small temperature drift, simple to use, and strong resistance to external disturbances. It is an ideal option for attitude measurement in photovoltaic power (PV), PTZ control, tower turbines monitoring and other industries.

FEATURES

- Single-axis inclinometer measurement
- Resolution: 0.02°
- Voltage input: 9~35V
- Product size: L55mm×W37mm×H24mm (customizable)
- Accuracy: 0.2°
- Measuring range: $\pm 180^\circ$
- IP67 protection
- Output interface: RS232/485/TTL optional

APPLICATIONS

- Industrial automatic leveling
- Medical devices
- PV automatic tracking
- Tower tilt monitoring
- Special valves
- Oil drilling equipment
- Industrial converters
- Crane tilt angle control

/// SPECIFICATIONS

Electrical Specifications

Parameters	Conditions	Min	Typical	Max	Units
Power supply		9	24	35	V
Operating current	Non-loaded	20	30	40	mA
Operating temperature		-40		-85	°C
Store temperature		-55		+100	°C

Performance Specifications

Measuring range(°)	Conditions	±10	±30	±60	±90	±180
Measuring axis		X	X	X	X	X
Accuracy(°)	Indoor	0.2	0.2	0.2	0.2	0.2
Resolution(°)		0.02	0.02	0.02	0.02	0.02
Zero temperature drift(°/°C)	-40~85°C	±0.01	±0.01	±0.01	±0.01	±0.01
Power on time	<3s	<3s	<3s	<3s	<3s	<3s
Frequency response (Hz)	100	100	100	100	100	100
MTBF	≥ 30000 hours/time					
Electromagnetic compatibility	according to GBT17626					
Insulation resistance	≥100MΩ					
Shock resistance	2000g,0.5ms,3times/axis					
Weight (g)	210 (package excluded)					

Resolution: The measured minimum change value that the sensor can detect and resolve within the measurement range.

Accuracy: The error between the actual angle and the Root mean square(RMS) of the measured angle of the sensor (≥16 times).



Mechanical Characteristic

Connector	Metal connector (standard cable is 1.5 m)
Protection level	IP67
Shell material	Magnesium alloy sanding oxidation
Installation	Three M4 screws



Package size

Product Size: L55*W37*H24 (mm)

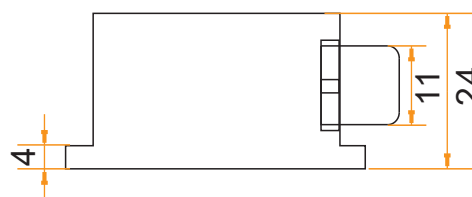
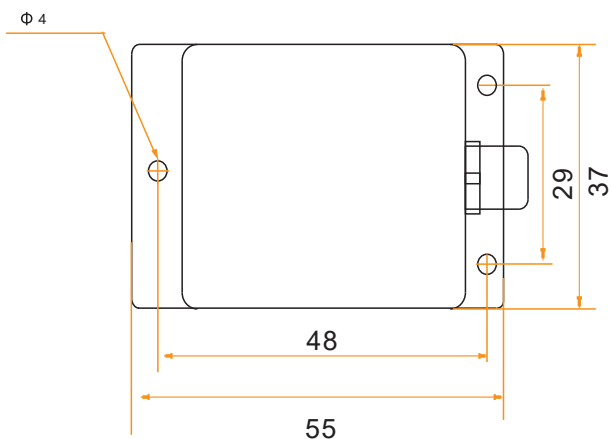

Bare plate product size

Product size: L33*W27*H6 (mm)

Note: ±1mm error for length and width dimensions, please refer to actual size.

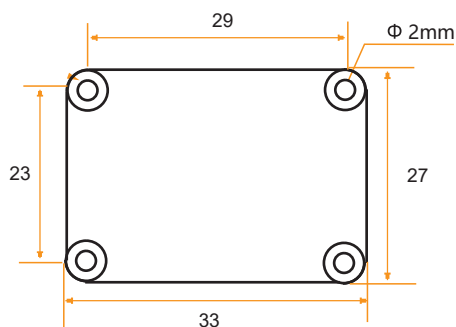

INSTALLATION DIRECTION

The correct installation method can avoid measurement error. The following points should be made when installing the sensor:

First of all, to ensure that the sensor mounting surface and the measured surface completely close, the measured surface should be as horizontal as possible, can not have the angle shown in Figure A and Figure C, the correct installation is shown in Figure B and Figure D.

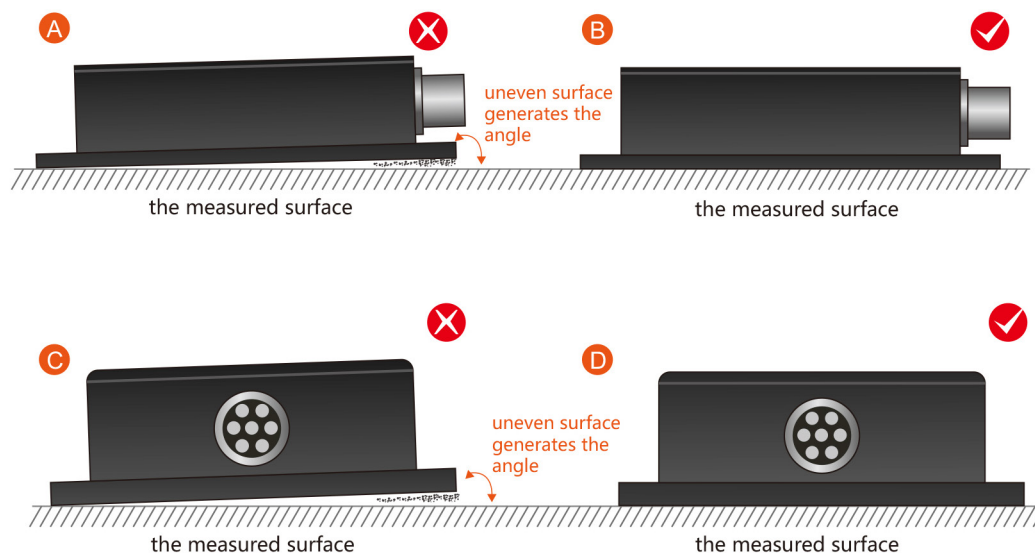

Secondly, the bottom cable of the sensor and the axis of the measured object shouldn't generate the angle shown in E. When installing, the bottom cable of the sensor should be kept parallel or orthogonal to the rotation axis of the measured object. This product can be installed horizontally or vertically (vertical installation requires customization). The correct installation method is shown in Figure F.

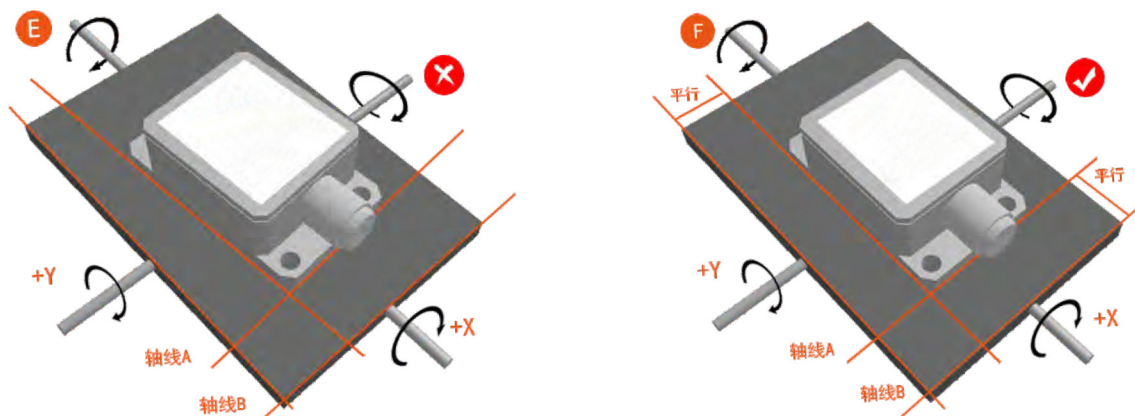

Finally, the installation surface of the sensor must be fixed with the measured surface tightly and smoothly, to avoid measurement error that may be caused by the acceleration and vibration.

ELECTRICAL CONNECTIONS

Electrical interfaces

Cable color & Function	Red	Blue	Black	Green	Yellow
	1	2	3	4	5
Function	VCC DC 9-35V	NC	GND	RXD (B, D-)	TXD (A, D+)

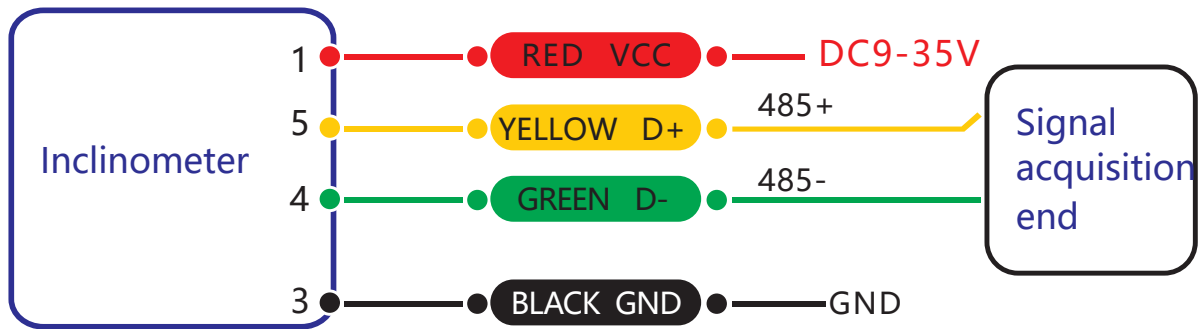

RS 485 wiring diagram

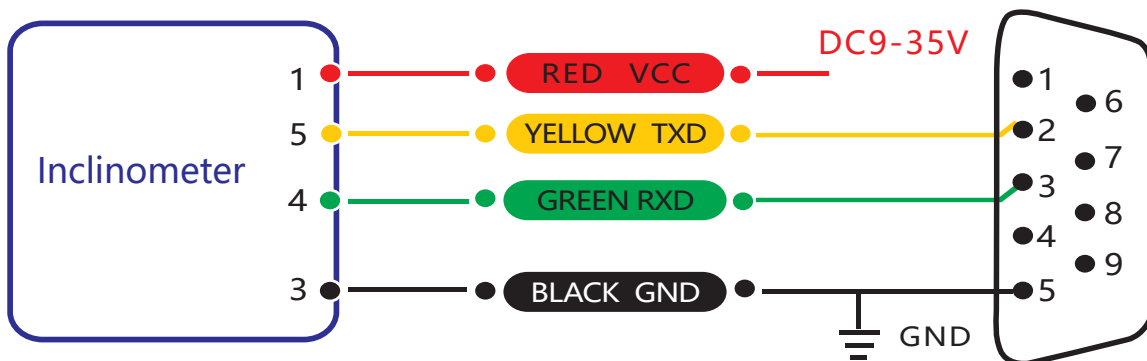

RS 232 wiring diagram

/// DEBUG SOFTWARE

Users can directly download serial assistant on official website (Supports-Download). You can also use more convenient and intuitive PC software.

IM-SA-RT02 supporting serial debugging software can be connected to the inclinometer on the computer for angle display. The software debugging interface is as shown in the figure below. Using the debug software, it can conveniently display the current X-direction tilt angle, and you can also modify and set other parameters by yourself.

Software use steps:

1. Correctly connect the inclinometer serial port hardware and connect the power supply.
2. Select the computer serial port and baud rate and click connect Serial Port.
3. Click Start and the tilt angle of the tilter in the X direction will be displayed on the screen.

Note: You can switch to Chinese or English version by the Upper right button

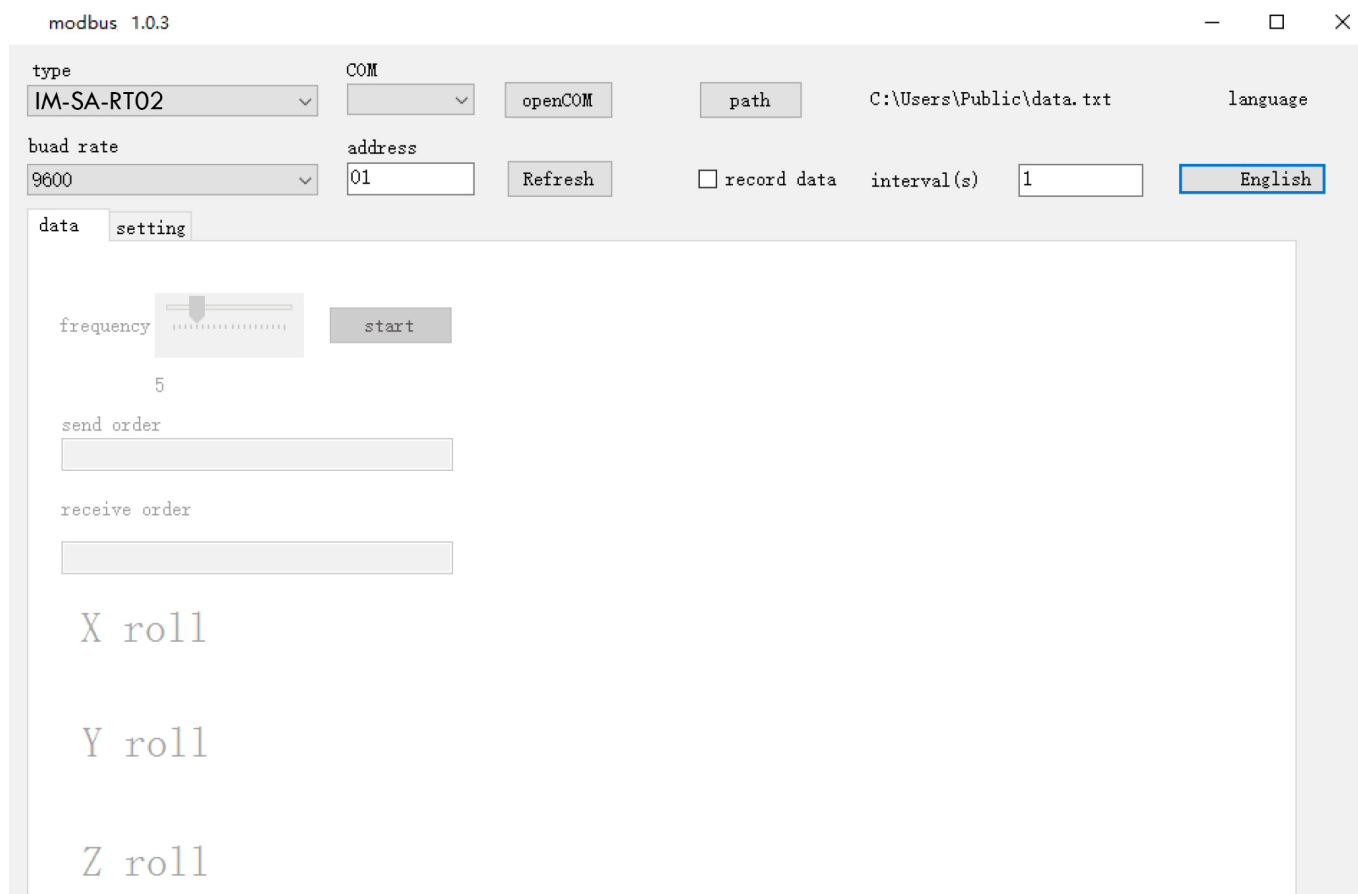

PROTOCOL

1. DATA FRAME FORMAT: (8 data bits, 1 stop bit, non verification, default rate 9600)

Address Code (1 byte)	Function Code (1 byte)	The first high address register (1 byte)	The first low address register (1 byte)	High register number (1 byte)	Low register number (1 byte)	Checksum (2 byte)
0x01	0x03 (read) 0x06 (write)	xx	xx	xx	xx	xxxx

Data format: Hexadecimal

Address code: Default 01 (**note:** it should not exceed FF)

Function Code: 03 represents reading register, 06 represents presetting register.

Register Address: The starting address the register need to be operated

Register amount: The amount need to operate

Checksum: It is calculated by the host. (We recommend that users need to use the CRC calculation software.)

2. COMMAND FORMAT:

2.1 Read angle of X-axis Command: 01 03 00 01 00 01 D5 CA

Address Code (1 byte)	Function Code (1 byte)	The first high address register (1 byte)	The first low address register (1 byte)	High register number (1 byte)	Low register number (1 byte)	Checksum (2 byte)
0x01	0x03	0x00	0x01	xx	0x01	0xD5CA

Command response:

Address Code (1 byte)	Function Code (1 byte)	Number of bytes (1 byte)	High number (1 byte)	Low number (1 byte)	Wrong CRC checksum (2 byte)
0x01	0x03	0x02	xx	xx	xxxx

Note: The data field is a hexadecimal number (PLC or configuration software reads the data directly with a 16-bit register is decimal). After converting to decimal, the real data = (data field -10000)/100. If the data field is 3D52, it is converted to decimal 15698, real data = (15698-10000)/100 = 56.98 degrees; the data field is 1230, converted into decimal 4656, real data = (4656-10000)/100 = -53.44 degree.

2.2 Set relative/absolute zero Command: 01 06 00 0A 00 00 A9 C8

Address Code (1 byte)	Function Code (1 byte)	The high address register (1 byte)	The low address register (1 byte)	Data field (2 byte)	Checksum (2byte)
0x01	0x06	0x00	0x0A	0000: absolute zero 0001: relative zero	0xA9C8

Command response:

Address Code (1 byte)	Function Code (1 byte)	The first high address register (1 byte)	The first low address register (1 byte)	Data field (2 byte)	Checksum (2byte)
0x01	0x06	0x00	0x0A	0000: absolute zero 0001: relative zero	0xA9C8

Note: absolute zero: Based on the factory-calibrated zero point.
relative zero: Reference to the zero after the current installation.

2.3 Query relative/absolute zero Command: 01 03 00 04 00 01 C5 CB

Address Code (1 byte)	Function Code (1 byte)	The first high address register (1 byte)	The first low address register (1 byte)	High register number (1 byte)	Low register number (1 byte)	Checksum (2 byte)
0x01	0x03	0x00	0x03	0x00	0x01	0xC5CB

Command response:

Address Code (1 byte)	Function Code (1 byte)	Number of bytes (1 byte)	High number (1 byte)	Low number (1 byte)	Wrong CRC checksum (2byte)
0x01	0x03	0x02	xx	xx	xxxx

2.4 Set module address Command: 01 06 00 0D 00 03 58 08

Address Code (1 byte)	Function Code (1 byte)	The first high address register (1 byte)	The first low address register (1 byte)	Data field (2 byte)	Checksum (2 byte)
0x01	0x06	0x00	0x0D	Module address	0xD9C9

Command response:

Address Code (1 byte)	Function Code (1 byte)	The first high address register (1 byte)	The first low address register (1 byte)	Data field (2 byte)	Checksum (2 byte)
0x01	0x06	0x00	0x0D	Module address	0xD9C9

2.5 Set communication rate Command: 01 06 00 0B 00 02 79 C9

Address Code (1 byte)	Function Code (1 byte)	The high address register (1 byte)	The low address register (1 byte)	Data field (2 byte)	Checksum (2byte)
0x01	0x06	0x00	0x0B	0x0002	0x79C9

Command response:

Address Code (1 byte)	Function Code (1 byte)	The high address register (1 byte)	The low address register (1 byte)	Data field (2 byte)	Checksum (2byte)
0x01	0x06	0x00	0x0B	0x0002	0x79C9

Note: 0000 represents 2400; 0001 represents 4800; 0002 represents 9600; 0003 represents 19200.

The default is 0002:9600.

Every time after changing the communication rate, the command response will be sent through the original rate. Then the rate will be changed.

2.6 Query the current address Command: 01 03 00 05 00 01 74 0A

Address Code (1 byte)	Function Code (1 byte)	The first high address register (1 byte)	The first low address register (1 byte)	High register number (1 byte)	Low register number (1 byte)	Checksum (2 byte)
0x01	0x03	0x00	0x03	0x00	0x01	0x740A

Command response:

Address Code (1 byte)	Function Code (1 byte)	Number of bytes (1 byte)	High number (1 byte)	Low number (1 byte)	Wrong CRC checksum (2byte)
0x01	0x03	0x02	xx	xx	xxxx

2.7 Save settings Command: 01 06 00 0F 00 00 B9 C9

Address Code (1 byte)	Function Code (1 byte)	The high address register (1 byte)	The low address register (1 byte)	Data field (2 byte)	Checksum (2 byte)
0x01	0x06	0x00	0x0F	0x0000	0x7809

Command response:

Address Code (1 byte)	Function Code (1 byte)	The high address register (1 byte)	The low address register (1 byte)	Data field (2 byte)	Checksum (2 byte)
0x01	0x06	0x00	0x0F	0x0000	0x7809

/// ORDERING INFORMATION

Product number	Way of communication	Package condition
IM-SA-RT02-180-232	RS232	IP67 Package/Metal Connector
IM-SA-RT02-180-485	RS485	IP67 Package/Metal Connector
IM-SA-RT02-180-TTL	TTL	IP67 Package/Metal Connector

/// EXECUTIVE STANDARD

- Enterprise Quality System Standard: ISO9001:2008 Standard (Certificate No.:10114Q16846ROS)
- CE certification (certificate number: 3854210814)
- ROHS (certificate number: SO81426003)
- GB/T 191 SJ 20873-2003 General specifications for tiltmeters and spirit levels
- GBT 18459-2001 sensor main static performance index calculation method
- JF 1059-1999 Evaluation and Expression of Measurement Uncertainty
- GBT 14412-2005 mechanical vibration and shock mechanical installation of accelerometer
- General requirements for GJB 450A-2004 equipment reliability
- Quality control of key parts and important parts of GJB 909A
- GJB 899 Reliability Qualification and Acceptance Test
- GJB 150-3A high temperature test
- GJB 150-4A low temperature test
- GJB 150-8A rain test
- GJB 150-12A dust test
- GJB 150-16A vibration test
- GJB 150-18A impact test
- GJB 150-23A Tilt and Swing Test
- GB/T 17626-3A RF electromagnetic radiation immunity test
- GB/T 17626-5A surge (hit) impulse immunity test
- GB/T 17626-8A power frequency magnetic field immunity test
- GB/T 17626-11A voltage dips, short interruptions and voltage changes immunity

IM-SA-RT02 Series

Modbus Single-Axis Inclinometer

Sat Control d.o.o.

Poženik 10
4207 Cerklje na Gorenjskem
Slovenia

Phone: +386 4 281 62 00

info@solar-motors.com
info@sat-control.si

www.solar-motors.com
www.sat-control.net

EU RoHS 



SAT CONTROL[®]
SOLAR TRACKERS